

# Successful Development of Common Firmware Supporting International Wireless Communication Standards Wi-SUN Enhanced HAN and Wi-SUN FAN 1.1

## Summary

The research group led by Professor Hiroshi Harada at the Graduate School of Informatics, Kyoto University, has successfully developed common firmware that operates on a single hardware platform for the international wireless communication standards “Wi-SUN Enhanced HAN” (used for in-home wireless networks in smart meter systems) and “Wi-SUN FAN” (used for outdoor wireless networks). This achievement is expected to reduce the cost of deploying wireless equipment for smart meter systems and contribute to more efficient infrastructure operation.

## Key Points

- Successfully developed unified firmware compatible with international wireless communication standards for both in-home and outdoor wireless networks
- Enables seamless connection of information collected from sensors, meters, and monitoring devices installed in homes and buildings to wide-area communication networks through multi-hop relay communication using up to 24 wireless devices
- The IoT routing functionality of Wi-SUN Enhanced HAN enables integrated meter reading for electricity, gas, and water meters

## 1. Background

To enable integrated meter reading of gas, water, and special-purpose meters using smart electricity meter systems, as well as applications such as HEMS (Home Energy Management Systems), the Wi-SUN Alliance—an international wireless standards organization—has established “Wi-SUN Enhanced HAN,” an international wireless communication standard for in-home wireless networks within smart meter systems. In addition to in-home applications, this standard has also been adopted by the Ministry of Economy, Trade and Industry’s “Next-Generation Smart Meter System Study Group” as a wireless standard for integrated meter reading, referred to as “IoT Routing,” which collects electricity, gas, and water meter data through electricity metering networks. Meanwhile, in the smart city and smart metering fields, there is a growing demand for IoT systems capable of collecting and controlling information from outdoor sensors, meters, and monitoring devices on a large scale—supporting hundreds of devices over wide geographic areas spanning several kilometers or more. Such systems require highly reliable and high-speed wireless networks that maintain excellent communication quality and fault tolerance even in environments obstructed by buildings and other structures. To address these requirements, the international wireless communication standard “Wi-SUN FAN” has been established. Until now, Wi-SUN Enhanced HAN and Wi-SUN FAN have been operated as separate standards, with in-home and outdoor networks managed independently. However, driven by initiatives such as integrated meter reading for gas and water meters

utilizing next-generation smart meters, the integration and interconnection of these two networks are progressing. To further advance seamless coordination between indoor and outdoor networks, there has been a strong demand to unify Wi-SUN Enhanced HAN and Wi-SUN FAN and integrate both communication profiles into a single hardware platform.

## 2. Research and Development Results

We successfully developed common firmware that operates on a single hardware platform and supports both the Wi-SUN Enhanced HAN communication standard—extended for IoT routing—and the Wi-SUN FAN 1.1 multi-hop communication standard for wide-area networks. This development was carried out in collaboration with Nisshin Systems Co., Ltd. The firmware incorporates the following functions specified in the technical specifications of Wi-SUN HAN 2.0 and Wi-SUN FAN 1.1.

- Physical and MAC layers compliant with IEEE 802.15.4/4g/4e
- Adaptation, network, and transport layers defined by the IETF, including technologies such as 6LoWPAN and IPv6
- One-to-many tree-structured communication with relay functionality (Wi-SUN Enhanced HAN)
- Multi-hop communication using RPL and frequency hopping (Wi-SUN FAN)
- Authentication and security functions

The firmware can be installed on any Wi-SUN-compatible wireless module.

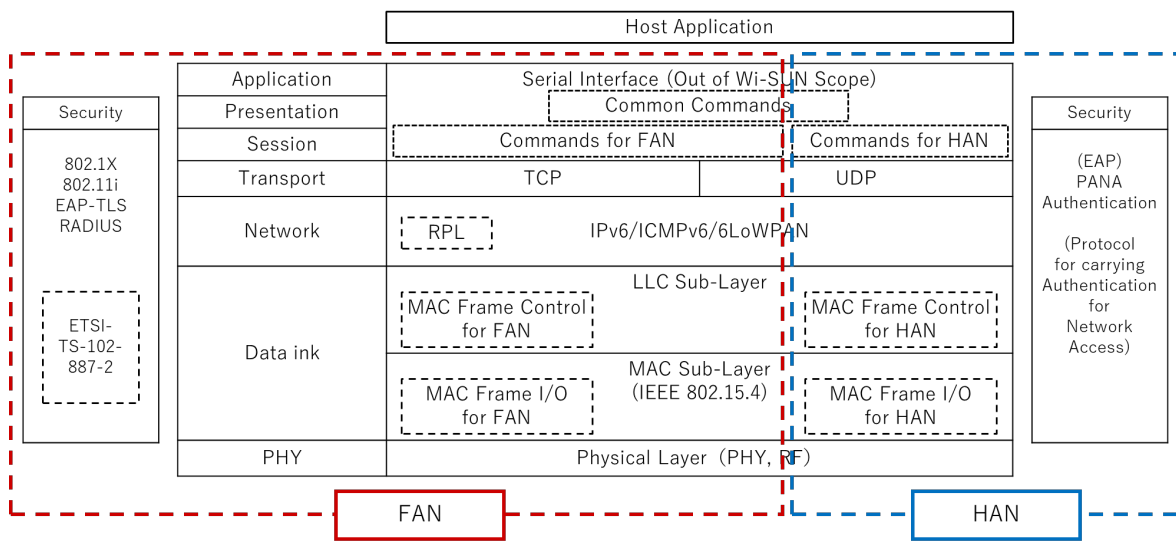

**Figure 1:** Functional Block Diagram



**Figure 2:** Wireless module equipped with common firmware

### 3. Future Plans

We plan to install the firmware developed through this project on a variety of Wi-SUN-compatible wireless modules and conduct large-scale integrated evaluations of both “Wi-SUN FAN” and “Wi-SUN Enhanced HAN.” In addition, through participation in events organized by the Wi-SUN Alliance, we will promote initiatives aimed at the social implementation and wider adoption of Wi-SUN Enhanced HAN and Wi-SUN FAN 1.1. Furthermore, the results of this project are scheduled to be exhibited at the Wi-SUN Alliance booth during the event “Wireless Japan × Wireless Technology Park 2026,” which will be held at Tokyo Big Sight from May 27 to May 29.

### 4. Acknowledgments

Part of this research includes results obtained through the National Institute of Information and Communications Technology (NICT)’s “Research and Development of Ultra-Coverage Beyond 5G Wireless Communication and Video Coding Standardization Technologies through Japan-U.S.-Australia International Collaboration (JPJ012368C05101)” and the Ministry of Internal Affairs and Communications’ “Research and Development for Expanding Radio Frequency Resources (JPJ000254).”

#### <Glossary>

1. Wi-SUN Enhanced HAN (Home Area Network)  
Wi-SUN Enhanced HAN is an extension of the Wi-SUN HAN standard established by the Wi-SUN Alliance, incorporating relay and sleep functions. It also specifies communication functions for IoT devices, including integrated meter reading for gas and water meters using smart electricity meter systems.
2. Wi-SUN FAN (Field Area Network)  
Wi-SUN FAN is an IPv6-based multi-hop wireless communication specification for sensors and meters established by the Wi-SUN Alliance. It is designed to support smart metering, smart grids for distribution automation, and smart city applications such as infrastructure management, intelligent transportation systems, and smart lighting. Version 1.0 was established in 2016, and Version 1.1, which supports higher-speed communication and lower power consumption, is currently in use.

\* The names of organizations and products mentioned in this document are registered trademarks or trademarks of their respective owners.